

Instruction Manual

PMD2XT-XX-0XX-A Digital Pyrometer

A. Specifications

- Power Supply: 9 to 16 VDC (optional 24 VDC)
- Power Consumption: < 2W
- Sampling Rate: 4 samples/second
- Accuracy: ±0.2% full scale ±1
- Display Range: -1999 ~ 9999
- Relay Contact Rating: 1A @ 30VDC
- Retransmit Open Circuit Voltage: 15V
- Case Dimensions: 48x24x75 mm
- Mounting Cutout Dimension: 45x22 mm
- LED Display: 0.28" (7 mm)
- Operating Temperature: 0 ~ 50C, <85% RH

B. Front Panel

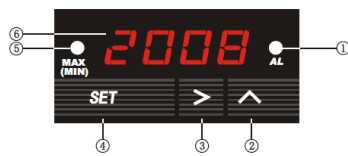

A. Specifications

- ① Alarm & relay J1 indicator
- ② Up key
- ③ Shift key
- ④ Set Key
- ⑤ Maximum & Minimum value indicator
- ⑥ Display Window

1. AL on indicates alarm is on & J1 relay is pulled in (closed)
2. MAX(MIN) on when display window shows the maximum value or the time of the MAX. MAX(MIN) blinking when display window shows the minimum value or the time of MIN.
3. ">" Shift key: In the parameter setting mode, press this key to select the digit to be changed. In the normal operation mode, press this key to change the display in the sequence shown in the diagram below.

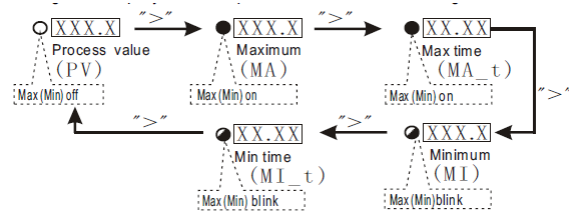

4. "▲" Up key: In the parameter setting mode, press this key to increase the displayed value. When displaying Max/Min, press & hold it for 3 seconds to clear the Max/Min stored. In normal function, this key has two functions, Show Operation Time & Change Display Brightness. Press & hold this key down to show the Operation Time since on. Release the key to display the current temperature (process value). Each time the key is pressed, the display brightness will also be changed from bright to dim or from dim to bright.



C. Parameter Setting

1. Basic Parameter

See [Fig3] for programming flow chart
(Press "SET" key then input code 0089 to enter)

Symbol	Description	Setting range	Initial	Note
<i>IntY</i>	Inty Input Type	See Table 1	<i>P</i>	
<i>PuL</i>	PuL Scale low	-1999~9999	0	4
<i>PuH</i>	PuH Scale high	-1999~9999	1000	4
<i>dot</i>	Decimal point	0000~0.000	0.000	4
<i>PSb</i>	PSb Zero offset	-1000~1000	0	1
<i>PSbF</i>	PSbF Range coefficient	0.500~2.000	1.000	2
<i>CorF</i>	CorF Temperature unit	C : °C F : °F	F	
<i>FILt</i>	FILt Digital filter	0~3	0	3
<i>End</i>	End Exit			

Note 1: for correcting the offset at Zero: Display = measurement + PSb
 Note 2: for correcting the error at Max: Display = measurement + PSbF
 Note 3: Digital filter: 0=no filter, 1=weak, 2=medium, 3=strong
 Note 4: These parameters define the scale boundary & resolution of the display value. They do not apply to temperature sensors.

[Table1] Input Type Options

Symbol	Input type	Range	Res.	Accy.	Impedance
<i>t</i>	TC, Type T	-200~400°C	1°C(F)	0.3%	100K
<i>r</i>	TC, Type R	-50~1600°C	1°C(F)	0.3%	100K
<i>J</i>	TC, Type J	-200~1200°C	1°C(F)	0.2%	100K
<i>WR E</i>	TC, WRe3-WRe25	0~2300°C	1°C(F)	0.2%	100K
<i>b</i>	TC, Type B	350~1800°C	1°C(F)	0.3%	100K
<i>S</i>	TC, Type S	-50~1600°C	1°C(F)	0.3%	100K
<i>P</i>	TC, Type K	-200~1300°C	1°C(F)	0.2%	100K
<i>E</i>	TC, Type E	-200~900°C	1°C(F)	0.2%	100K
<i>P100</i>	RTD, Pt100	-199.9~600.0°C	0.1°C(F)	0.2%	(0.2mA)
<i>Cu50</i>	RTD, Cu50	-50.0~150.0°C	0.1°C(F)	0.5%	(0.2mA)
<i>375r</i>	0~375 Ω Pressure			0.2%	(0.2mA)
<i>75mV</i>	0~75mV Current			0.1%	100K
<i>30mV</i>	0~30 mV			0.1%	100K
<i>5V</i>	0~5 V			0.1%	100K
<i>1-5V</i>	1~5 V			0.1%	100K
<i>10V</i>	1~10 V			0.1%	100K
<i>10mA</i>	0~10 mA			0.3%	150Ω
<i>20mA</i>	0~20 mA			0.2%	150Ω
<i>4-20</i>	4~20 mA			0.2%	150Ω

(TC = Thermocouple Sensor)

2. Alarm Parameter

(Press "SET" key then input code 0001 to enter)

Symbol	Name	Description	Range	Initial	Note
<i>AH1</i>	AH1	J1 pull in Value	-1999~9999	900	4
<i>AL1</i>	AL1	J1 drop out value	-199~9999	800	
<i>AH2</i>	AH2	J2 pull in Value	-1999~9999	900	
<i>AL2</i>	AH2	J2 drop out Value	-1999~9999	800	
<i>End</i>	End	Exit			

Alarm Parameter setting is similar to the Basic Parameters setting in [Fig3] except the access code is 0001 instead of 0089

Note 4: Relay action setting (PMD-A meter does not contain J2 relay. Its settings (AH2 & AL2 can be ignored).

- 1) Set AH1=AL1, relay is disabled
- 2) Set AH1>AL1, relay is for high alarm limit. See [Fig1]
- 3) Set AH1<AL1, relay is for low limit alarm. See [Fig2]

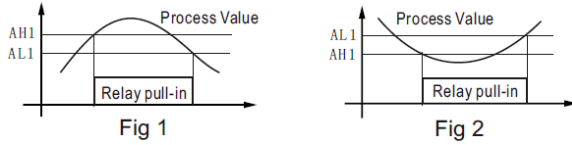

[Fig3] Basic Parameter setting flow chart

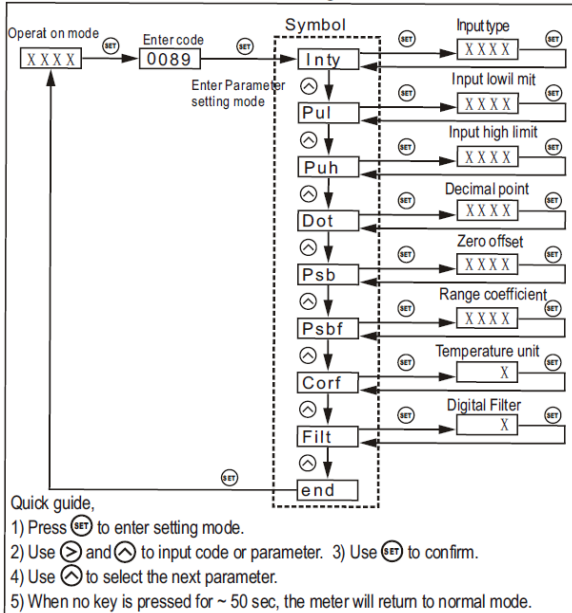

3. Peak Value

(Press "SET" key then input code 0037 to enter)

Symbol	Name	Description	Range	Initial	Note
MA	MA	Maximum value	0 n / 0 FF	0 n	5
MA-t	MA-t	Time of maximum	0 n / 0 FF	0 FF	
MI	MI	Minimum value	0 n / 0 FF	0 FF	
MI-t	MI-t	Time of minimum	0 n / 0 FF	0 FF	
End	End	End			

Note 5: Peak function is interlocked.

- 1) When MA is turned off, MA-t can't be set
- 2) When MI is turned off, MI-t can't be set

Peak Value setting is similar to the Basic Parameters setting in [Fig3] except the access code is 0037 instead of 0089

Reset the Peak value:

The peak values are stored in the memory even after the meter is powered off. To reset them, change the display to show MA, MA-t, MI, or MI-t. Then, press & hold "▲" key for 3 seconds. The display will show "—" indicating the memory (for all four parameters) is reset. The meter will start to catch the new peak after 2 seconds.

4. Retransmit (Analog Output)

(Press "SET" key then input code 0036 to enter)

Symbol	Name	Description	Range	Initial	Note
oby	oby	Output type	0-20/4-20 mA	4-20	6
obL	obL	output low limit	-1999-9999	000.0	7
obH	obH	output High limit	-1999-9999	100.0	8
End	End	Exit			

Retransmit setting is similar to the Basic Parameters setting in [Fig3] except the access code is 0036 instead of 0089

Note 6: Output type section. User can select either 0-20 mA or 4-20 mA.

Note 7: Output lower limit. The LED display value when output is at 0 mA or 4 mA.

Example: If you want 100C to output 0 mA then set obL=100

Note 8: Output high limit. The LED display value when output is at 20 mA.

Example: If you want 1000C to output 20 mA then set obH=1000

This number will affect the resolution of the signal

D. Terminal Assignment

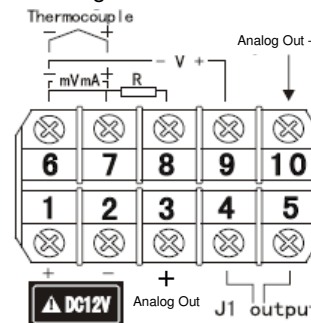

- 1) 1 & 2 are for power input
- 2) 4 & 5 are for alarm relay output. When alarm is turned on, terminals 2 & 5 are internally connected. To drive a 12V buzzard, connect one lead of the buzzard to the +12V. Connect the other lead to terminal 5.
- 3) 6, 7, 8, & 9 are for different type of signal input. Example: Use 6 & 7 for EGT thermocouple probe.
- 4) 3 & 10 are for retransmit (analog output). 1-5VDC or 0-5VDC (depending on "oby" setting)

E. Application Example

Exhaust Gas Temperature Measurement

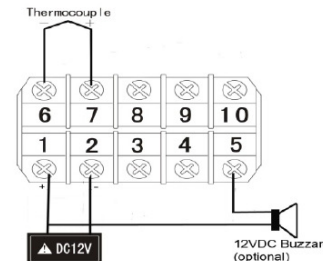

The Sensor Connection

55 East Long Lake Road, #505, Troy, MI 48085 USA

Tel: 248-636-1515 sales@thesensorconnection.com