



SPRING-LOADED AC-LVDT

Position Sensors

MACRO GHSA 750 | GHSAR 750

Overview

The Macro Sensors GHSA 750 and GHSAR 750 series of 3/4 inch diameter spring loaded AC-LVDTs are designed for a wide range of position measurement and dimensional gaging applications. These rugged hermetically sealed sensors are constructed entirely of stainless steel and intended for general industrial use. The coil windings are sealed against hostile environments to IEC standard IP-68. The GHSA 750 electrical termination is through a sealed axial connector. The GHSAR 750 electrical termination is through a radially mounted sealed connector, which results in a much reduced installed length. The mating connector plug is supplied with the unit.

The sensor consists of a spring loaded shaft running in a precision sleeve bearing and connected to the core of an LVDT. The use of a precision sleeve bearing results in measurement repeatability of 0.01% of full range or better. The output from the LVDT can be connected to any standard LVDT signal conditioner and then passed to a gaging column display, digital readout, or computer based data acquisition system. The probe shaft is fully extended by a spring exerting a nominal force of 6 to 20 ounces depending upon total range. The contact tip supplied is an AGD standard number 9 made from chrome plated hardened tool steel. It is fully interchangeable with other AGD contact tips.

Available in ranges of ± 0.050 inch (± 1.25 mm) to ± 2.00 inches (± 50.0 mm), the maximum linearity error for a GHSA 750 Series sensor is $\pm 0.25\%$ of full range output using a statistically best-fit straight line derived by the least squares method.

For simplified mounting the GHSA 750 has a 1/2-20 UNF 2A thread on the front of the housing, permitting the user to install the LVDT in a mating threaded part or by using the two hex nuts furnished with the sensor. This results in a ready-to-use package for position measurements and longer range gaging applications.

All GHSA 750 Series LVDTs will operate properly with any conventional differential input LVDT signal conditioners, but operation with ratiometric LVDT signal conditioning is not recommended.

SPRING-LOADED AC-LVDT

GHSA 750 | GHSAR 750

Benefits

- Ranges of ± 0.050 inch to ± 2.00 inches
- Repeatability of 0.01% of FRO
- Non-linearity less than $\pm 0.25\%$ of FRO
- Coil environmentally sealed to IEC IP-68

Applications

- Industrial gaging systems
- Electronic dial indicators
- Fabricated metal products gaging
- Materials testing apparatus
- Large shaft TIR measurements

General Specifications

Input Voltage	3.0 V_{rms} (nominal)
Input Frequency	2.5 to 3.0 kHz
Linearity Error	$\leq \pm 0.25\%$ of FRO
Repeatability Error	$< 0.01\%$ of FRO
Operating Temperature	-65°F to +220°F (-55°C to +105°C)
Thermal Coefficient of Sensitivity	-0.01%/°F (nominal) (-0.02%/°C nominal)

Dimensions

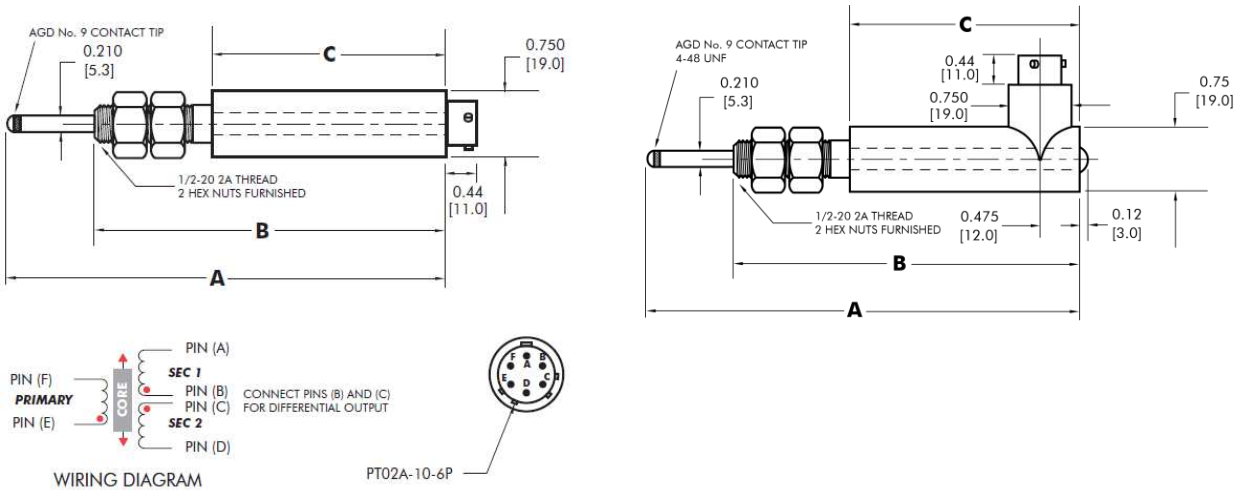

All dimensions in inches [mm]

SPRING-LOADED AC-LVDT

GHSA 750 | GHSAR 750

Specifications

Model ▶ Parameter ▼	GHSA 750 -050	GHSA 750 -125	GHSA 750 -250	GHSA 750 -500	GHSA 750 -1000	GHSA 750 -2000
Model ▶ Parameter ▼	GHSAR 750 -050	GHSAR 750 -125	GHSAR 750 -250	GHSAR 750 -500	GHSAR 750 -1000	GHSAR 750 -2000
Nominal Range (inches)	±0.050	±0.125	±0.25	±0.50	±1.00	±2.00
Nominal Range (mm)	±1.25	±3.0	±6.3	±12.5	±25.0	±50.0
Sensitivity (mV/V/.001 in)	6.1	3.9	2.5	0.65	0.61	0.37
Sensitivity (mV/V/mm)	240	153	98	26	24	14
Primary Impedance (Ω)	325	735	1400	1200	1250	2150
Pretravel (inches)	0.12	0.13	0.10	0.10	0.05	0.02
Pretravel (mm)	3.0	3.3	2.5	2.5	1.3	0.5
Overtravel (inches)	0.12	0.13	0.10	0.10	0.05	0.02
Overtravel (mm)	3.0	3.3	2.5	2.5	1.3	0.5
Dimension "A" (inches)	4.61	5.26	6.02	10.54	12.81	20.91
Dimension "A" (mm)	117	134	153	268	322	531
Dimension "B" (inches)	3.51	4.15	4.91	9.05	10.51	16.35
Dimension "B" (mm)	89	105	125	230	267	415
Dimension "C" (inches)	1.97	2.60	3.35	5.88	7.34	10.87
Dimension "C" (mm)	50	66	85	149	186	276
Weight (ounces)	2.9	3.4	4.0	6.0	6.3	10.2
Weight (g)	82	96	113	170	179	290

Ordering Information

Order by model number with range. For accessories and compatible signal conditioners, please contact the factory.

NORTH AMERICA

AST Macro Sensors,
a TE Connectivity company
7300 US Route 130 North
Pennsauken, NJ 08110-1541 USA
Tel +1 856 662 8000
Fax +1 856 317 1005
sales@macrosensors.com

TE.com/sensorsolutions

AST Macro Sensors, a TE Connectivity company.

AST Macro Sensors, TE Connectivity, TE Connectivity (logo) and EVERY CONNECTION COUNTS are trademarks. All other logos, products and/or company names referred to herein might be trademarks of their respective owners.

The information given herein, including drawings, illustrations and schematics which are intended for illustration purposes only, is believed to be reliable. However, TE Connectivity makes no warranties as to its accuracy or completeness and disclaims any liability in connection with its use. TE Connectivity's obligations shall only be as set forth in TE Connectivity's Standard Terms and Conditions of Sale for this product and in no case will TE Connectivity be liable for any incidental, indirect or consequential damages arising out of the sale, resale, use or misuse of the product. Users of TE Connectivity products should make their own evaluation to determine the suitability of each such product for the specific application.

© 2015 TE Connectivity Ltd. family of companies All Rights Reserved.

GHSA 750 | GHSAR 750 11/01/15