

2-Stroke Exhaust Gas Temperature Probe - 90 Degree Bend

EGT Temperature Probe for 2-Stroke Engines

- Type K thermocouple probe
- Enclosed anti-fouling sensing junction
- Includes 316 SS adjustable compression fitting
- Stainless steel protected wires
- Designed for optimal performance in 2-Stroke Engines

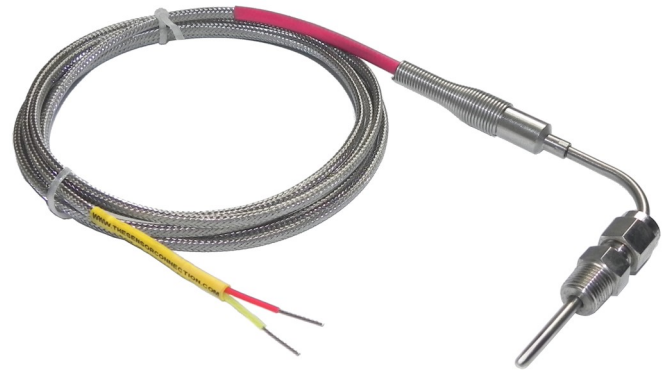

Specifications

Thermocouple type: K
 Range: -148 to 2372°F (-100 to 1300°C)
 Accuracy: +/-0.4% of reading or about +/- 1.1°C (Special Limits of Error)

Probe diameter: 1/8 inch (0.125 inch) (3.17 mm)
 Sensing Junction: Enclosed, Ungrounded
 Response Time*: 550 mS
 *Time Constant: Defined as the time required to reach 63.2% of an instantaneous temperature change
 Five time constants are required to approach 100% of the step change value

Outer Sheath Material: Inconel, melting point 2550°F (1400°C)

Cable: Stainless steel overbraiding over Teflon™ insulated, stranded wires, 20 gage

Compression Fitting: 316 stainless steel, adjustable, 1/8 inch -27 NPT male thread

Wiring: + = Yellow - = Red

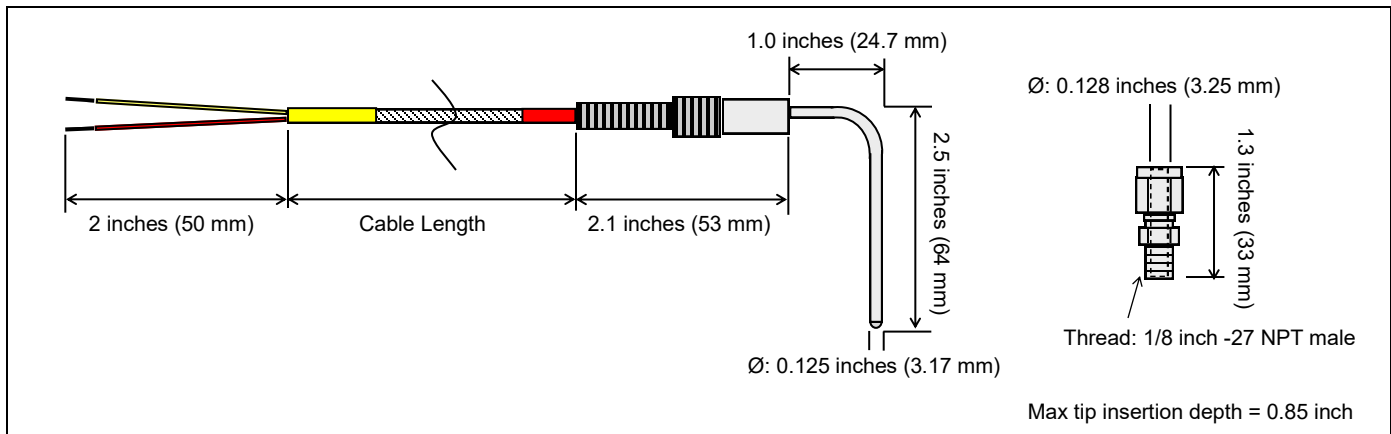

Ordering Information

Model	Cable Length			Connector
EGT-2S	-□□□	-0251	-SS	-□
	072 72 inches 144 144 inches 300 300 inches			N No connector MP Male mini-plug SP Standard plug

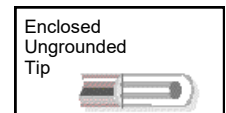

Ordering Example

EGT-2S-072-0251-SS-N: 72 inch long cable, Type K thermocouple, no connector