

HSD 750 Series

Hermetically Sealed DC-LVDT Position Sensors



Description

Macro Sensors' HSD 750 Series of 3/4 inch (19 mm) diameter DC-operated LVDTs is designed for a wide range of position measurement applications. These are rugged hermetically sealed sensors, constructed entirely of stainless steel, and intended for general industrial use. The coil windings are sealed against hostile environments to IEC standard IP-68 and electrical termination is through a sealed axial connector. The mating connector plug is supplied with the unit.

HSD 750 Series sensors use built-in electronics to provide the desirable features of an AC-LVDT, such as frictionless operation and dynamic response, with the added convenience and simplicity of DC input and precalibrated DC output. They are designed to operate in conjunction with PLCs, digital indicators, A/D converters, computer-based data processors and QC data collection systems.

Features

- Ranges of ± 0.050 inch to ± 10.0 inches
- In-line connector, mating plug included
- Environmentally sealed to IEC IP-68
- ± 15 V DC input, precalibrated 0 to ± 10 V DC output
- Non-linearity less than $\pm 0.25\%$ of FRO

Applications

- Machine tool positioners
- Materials testing extensometers
- Hydraulic cylinder position
- Valve position sensing
- Automatic assembly equipment
- Corrosive environments

Available in ranges of ± 0.050 inch (± 1.25 mm) to ± 10.0 inches (± 250 mm), the HSD 750 Series sensors feature the high resolution, excellent repeatability, and low hysteresis associated with LVDT technology. Their exceptional reliability is a result of manufacturing processes and assembly techniques developed and optimized by Macro Sensors over many years of manufacturing LVDT sensors. The maximum linearity error for any of these sensors is $\pm 0.25\%$ of full range output using a statistically best-fit straight line derived by the least squares method.

Macro Sensors offers several standard options that permit a user to customize HSD 750 LVDTs, including Teflon® bore liners and metric threaded cores. In addition, Macro Sensors can provide mounting accessories, core extension rods, and DC power supplies.

General Specifications

- Input Power:** ±15 V DC, ±25 mA
- Full Scale Output:** 0 to ±10 V DC
- Output Noise & Ripple:** <10 mV_{rms}
- Frequency Response (-3dB):** 250 Hz (nominal)
- Linearity Error:** <±0.25% of FRO
- Repeatability Error:** <0.01% of FSO
- Hysteresis Error:** <0.01% of FSO
- Operating Temperature:** 0°F to +160°F (-20°C to +70°C)
- Thermal Coefficient of Scale Factor:** -0.015%/°F (nominal) (-0.027%/°C nominal)
- Vibration Tolerance:** 20 g to 2 kHz
- Shock Survival:** 100 g, 11 ms

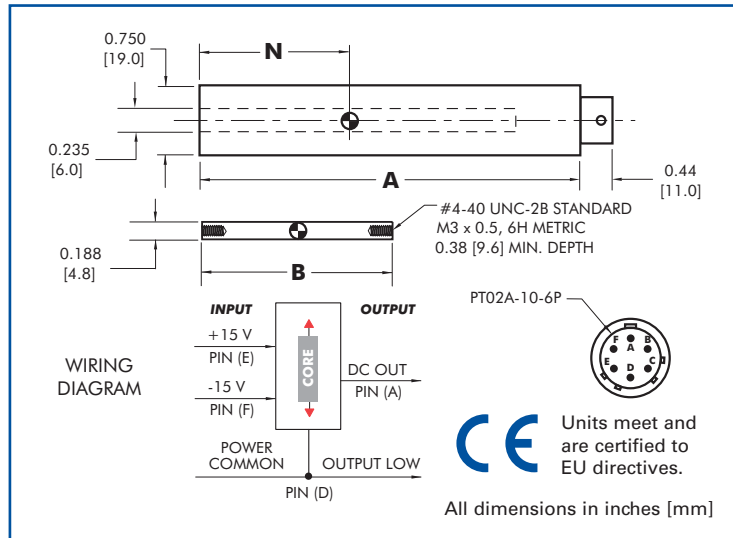

Specifications

Model ▶	HSD 750 -050	HSD 750 -125	HSD 750 -250	HSD 750 -500	HSD 750 -1000	HSD 750 -2000	HSD 750 -3000	HSD 750 -5000	HSD 750 -7500	HSD 750 -10000
Nominal Range (inches)	±0.050	±0.125	±0.25	±0.50	±1.00	±2.00	±3.00	±5.00	±7.50	±10.00
Nominal Range (mm)	±1.25	±3.0	±6.3	±12.5	±25	±50	±75	±125	±190	±250
Scale Factor (V/inch)	200	80	40	20	10	5.0	3.3	2.0	1.33	1.0
Scale Factor (V/mm)	8.0	3.3	1.6	0.8	0.4	0.2	0.13	0.08	0.05	0.04
Dimension "A" (inches)	2.86	3.48	4.24	6.74	8.24	11.21	14.49	19.49	25.00	32.38
Dimension "A" (mm)	72.5	88.3	107.7	171.2	209.3	284.7	368.0	495.0	635.0	822.5
Dimension "B" (inches)	0.80	1.25	1.65	3.45	3.45	5.30	6.20	6.20	7.00	9.50
Dimension "B" (mm)	20.3	31.7	41.9	87.6	87.6	134.6	157.5	157.5	177.8	241.3
Dimension "N" (inches)	0.63	1.13	1.35	2.57	3.33	5.07	6.45	8.95	11.52	15.42
Dimension "N" (mm)	16.0	28.8	33.8	65.4	84.6	128.8	163.8	227.3	292.6	391.6
Weight - Body (ounces)	1.9	2.5	3.1	4.1	4.9	8.3	10.3	12.1	16.3	20.4
Weight - Body (g)	54	68	80	114	140	236	292	342	462	579
Weight - Core (ounces)	0.08	0.12	0.18	0.40	0.40	0.65	0.80	0.80	0.90	1.20
Weight - Core (g)	2.4	3.7	4.8	11.6	11.6	18.0	22.0	22.0	25.5	34.0

Ordering Information

- For standard HSD 750, order by model number with range.
- For metric threaded core option, add -006 after model number with range.
- For Teflon® bore liner option, add -010 after model number with range.
- For both options, add -016 after model number with range.
- For accessories, please visit our website at www.macrosensors.com.



Innovators in Position Sensing

All specifications subject to change without notice.
 © 2002 Macro Sensors 11/01/02

7300 US Route 130 North, Bldg. 22
 Pennsauken, NJ 08110-1541 USA
 tel: 856-662-8000
 fax: 856-317-1005
www.macrosensors.com
lvdts@macrosensors.com

