

TEMPERATURE SENSOR

EXHAUST TEMPERATURE PROBE 2.5" STRAIGHT - 3/16" O.D.

Fast Response EGT Temperature Probe

FEATURES

- Type K thermocouple probe
- Exposed sensing junction for fastest response
- Includes 316 SS adjustable compression fitting
- Stainless steel protected wires
- Designed for engine test & racing environments



SPECIFICATIONS

Thermocouple type: K
Range: -148 to 2372°F (-100 to 1300°C)
Accuracy: +/-0.4% of reading or about +/- 1.1°C (Special Limits of Error)
Probe diameter: 0.090 inch (2.3 mm)
Sensing Junction: Exposed, Ungrounded
Response Time*: 250 mS
***Time Constant:** Defined as the time required to reach 63.2% of an Instantaneous temperature change. Five time constants are required to approach 100% of the step change value
Outer Sheath Material: Inconel, melting point 2550°F (1400°C)
Cable: Stainless steel overbraiding over Teflon™ insulated, stranded wires, 20 gage, rated to
Compression Fitting: 316 stainless steel, adjustable, 1/8 inch -27 NPT male thread
Wiring: + = Yellow - = Red

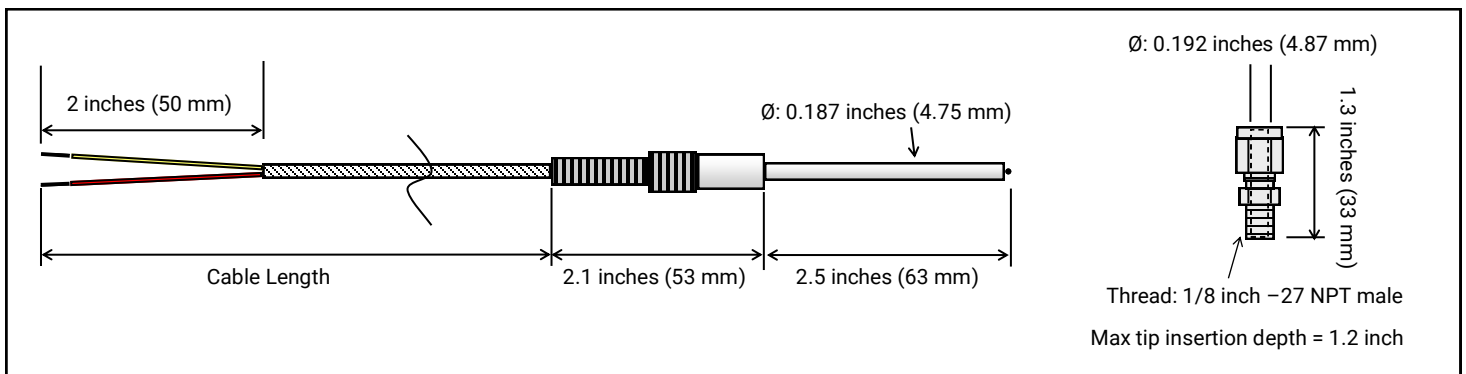

ORDERING INFORMATION

Model	Cable Length			Connector
EGT-EP	- □□□	-S251	-SS	- □
	072 72 inches 144 144 inches 300 300 inches			N No connector MP Male mini-plug SP Standard plug

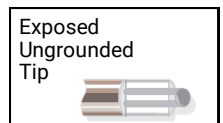

EXAMPLE

EGT-EP-072-S251-SS-N: 72 inch long cable, Type K thermocouple, no connector

